



The complete mixer/refiner WIECON for the batchwise production of chocolate mass, compound, coatings, cream and bread spreads

Introduction to the WIECON

The WIECON is the complete answer to produce small batches of coatings, compounds and bread spreads.

A steadily increasing number of users of above-mentioned products have realized both the technical and the financial advantages to manufacture its own products in accordance with its own requirements.

A variety of mixers, homogenisers and refiners have been made available over the years, each system offering a specific advantage closely related to the customer's wishes.

WIENER has developed and introduced the WIECON, which combines the advantage of manufacturing a variety of smaller quantities with a justified investment.

The Wiecon 25

The WIECON 25 produces batches of 275 kg each and the time to obtain an end fineness of 20-25 microns will be some 2.5 hours (up to 100 kg/hr) if granulated sugar (with a maximum size of 1 mm) is used as an ingredient. When powdered sugar is applied, the total processing time can be reduced to approximately 1.5 hours (up to 125 kg/hr).

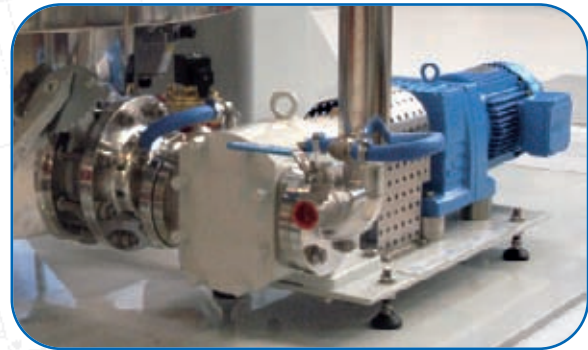

The Wiecon 50

The WIECON 50 produces batches of approximately 450 kg each and the time to obtain an end fineness of 20-25 microns will be some 2.5 hours (up to 150 kg/hr) if granulated sugar (with a maximum size of 1 mm) is used as an ingredient. When powdered sugar is applied, the total processing time can be reduced to approximately 1.5 hours (up to 200 kg/hr).

The production process

The mixing/grinding tank of the WIECON is especially designed to perform two basic functions, mixing of the ingredients and refining the mass down to the required fineness. These two functions take place simultaneously during production of the batch.

The machine is supplied with a circulation system, consisting of a circulation pipe with a temperature gauge for product temperature read-out, a 3-way valve and a jacketed WIENER lobe pump, driven by a 2.2 kW electric geared motor. During the process this pump sees to a continuous circulation of the product, from underneath the grinding tank through the circulation pipe back into the tank.

At the end of the process the product is discharged by switching the above 3-way valve to discharge position.





Technical specifications

WIECON 25 AND WIECON 50

Advantages:

- No foundations required.
- Extremely low power consumption.
- Excellent product fineness and homogeneity.
- Very good particle-size distribution.
- Consistent product quality.
- Easy to clean.
- Process expertise not required.

Duyvis Wiener will be very pleased to make the pilot plant in its laboratory available to conduct tests in order to establish the most suitable recipe for your individual requirement.

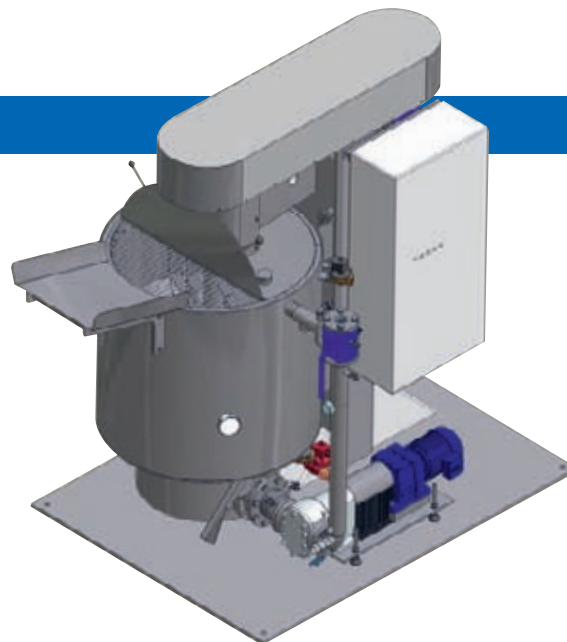

Dimensions / data:

| Type | Batch capacity | Processing time* (20-25 micron) | Ball charge | Pump motor | Main motor | Weight | Dimensions (lxwxh) |
|-----------|----------------|---|-------------|------------|------------|---------|--------------------|
| Wiecon 25 | up to 275 kg | 90-180 minutes powder, sugar - crystal sugar | 340 kg | 2.2 kW | 11 kW | 1700 kg | 2075x1540x1970 mm |
| Wiecon 50 | up to 450 kg | 90-180 minutes powder, sugar - crystal sugar | 680 kg | 2.2 kW | 22 kW | 2200 kg | 2430x1500x2065 mm |

* Processing time will vary depending on the type of recipe, usage of ingredients and the initial and end-fineness.

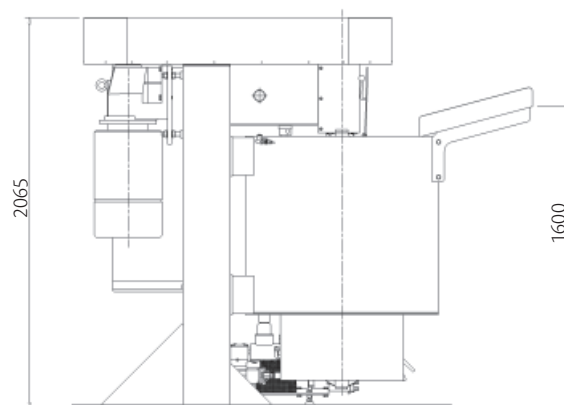
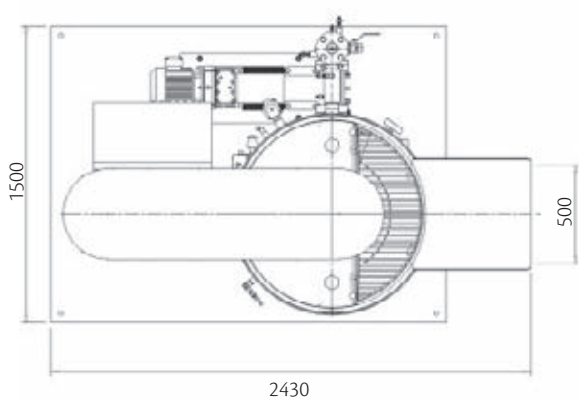

Wiecon 50

Duyvis and Wiener

B.V. Machinefabriek P.M. Duyvis is a machine-building company with more than 120 years of experience. It is situated in the oldest industrial region of the Netherlands where most of the cocoa and cocoa butter processing factories are located.

Duyvis is specialized in engineering, producing and installing processing machines for the cocoa and chocolate industry. With its excellent engineering and mechanical team Duyvis holds an impressive record in providing innovative solutions to the industry in general and the cocoa and chocolate industry in particular.

Duyvis is also specialized in modifying, overhauling, repairing and maintaining all kinds of equipment worldwide. The Duyvis team is able to provide a technological solution to every problem, paying attention to preventive maintenance and striving to find the best technical solutions and operating practices.

Since 2004 **Wiener** is part of the Duyvis Group. Wiener is an innovative and dynamic company with a strong position in the cocoa, chocolate and confectionary market. It is worldwide recognized as manufacturer and supplier of cocoa and chocolate process machinery and turn-key projects for cocoa, chocolate/compound, ice cream, bakery and the candy industry.

Wiener and Duyvis engineers, start-up technicians and process development experts joined forces and are working side by side to guarantee process and product innovations. The integrated laboratory in Koog aan de Zaan is available for testing food products in general and cocoa, chocolate, cream and compound in particular. A database of more than 25 years of data is available.

The combined know-how of Duyvis and Wiener will ensure the continuation of the high quality standard as well as excellent service. This is the result of combining two companies, which have together more than 200 years of experience.

Contact us and we will help you reduce your processing costs of cocoa, compound and chocolate production.



COCOA, COMPOUND AND CHOCOLATE EQUIPMENT

WWW.DUYVISWIENER.COM



P.O. Box 10
1540 AA Koog a/d Zaan
The Netherlands

Schipperslaan 15
1541 KD Koog a/d Zaan
The Netherlands

Phone: +31 75 6 126 126
Fax: +31 75 6 158 377
Email: sales@duyviswiener.nl



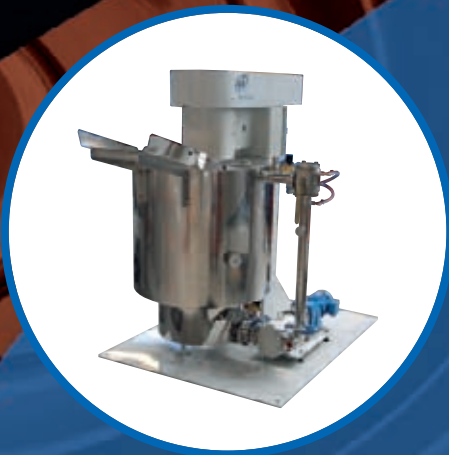

WIECON

MIXER REFINER OF COMPOUND



WIENER