

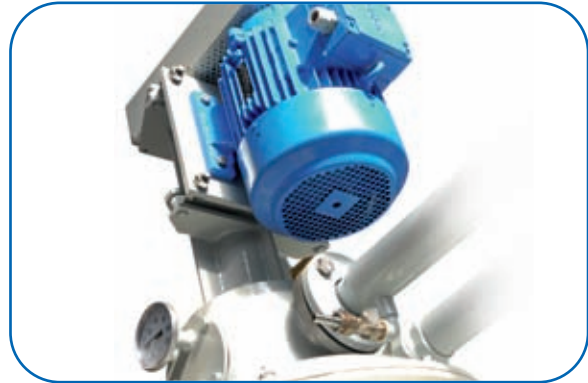

## Taste-Changer designed for the chocolate production process for conching and vaporizing effect

*The Taste-Changer, a WIENER invented unit, has one of the most important functions in the chocolate production process. It is a combination of a shear stress device and a very efficient film evaporator. Hot, dry air and chocolate are intensively brought into contact with one another, causing the moisture, volatile amino acids and off-flavours to be extracted from the mixture. The shear stress device temporarily reduces the viscosity of the mixture, thereby increasing the efficiency of the film vaporizer.*

*It is remarkable to note that the addition of pins has resulted in a butter saving of 0.6 % reaching the same viscosity and yield values.*



The system consists of one taste changer, driven by a 7.5 kW motor and 1 set of 3000 VA inserted heating elements. A ventilator, 0.66 kW, which supplies air to the Taste-Changer is provided.

The product-contactparts of the Taste-Changer are executed in stainless steel.

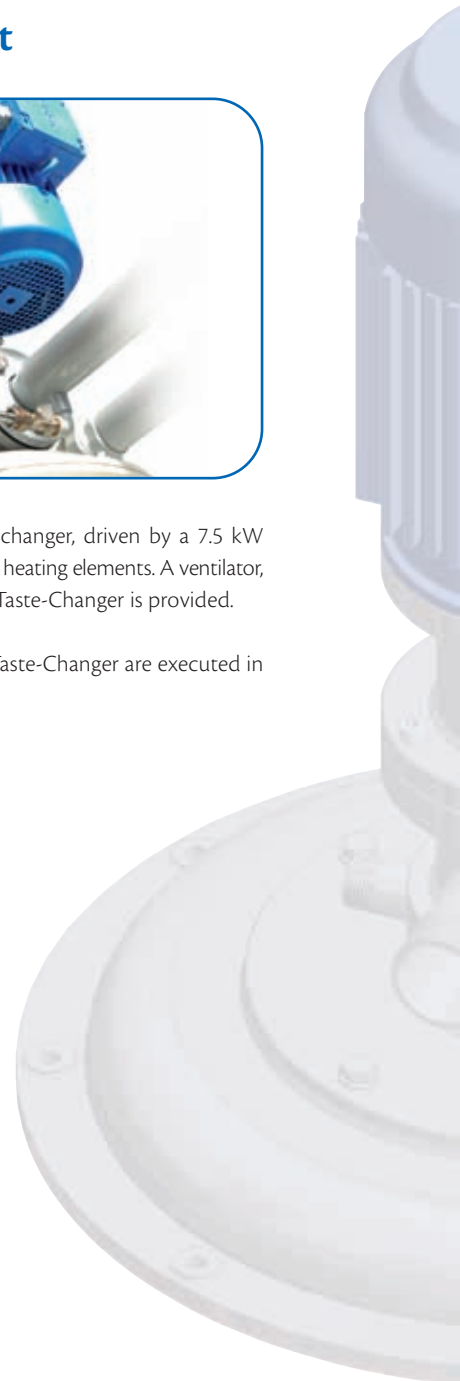



## Technical specifications

### TASTE-CHANGER

#### Advantages:

- Creating a conching effect to the product by adding shear stress;
- Improvement of viscosity by adding shear stress;
- Efficient removal of moisture and off-flavors by blowing hot air through a thin product-layer;
- Easy to install in an existing production line on a storage tank;
- Flexible to determine required circulation time.

#### Weights

<b>Taste-Changer</b>	185 kg
<b>Fan</b>	20 kg
<b>Total dynamic load (incl. piping)</b>	235 kg

#### Installed power

<b>Main motor</b>	7.5 kW (50 Hz)
<b>Fan</b>	0.66 kW (50 Hz)
<b>Heating</b>	3 kW (50 Hz)

#### General

<b>Shaft speed (at 50 Hz)</b>	3000 rpm
<b>Fan speed (at 50 Hz)</b>	2825 rpm

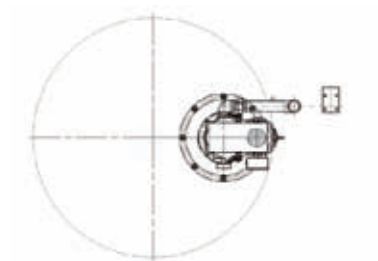
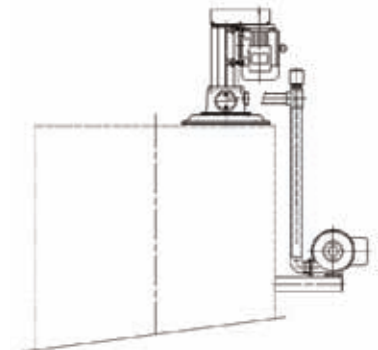
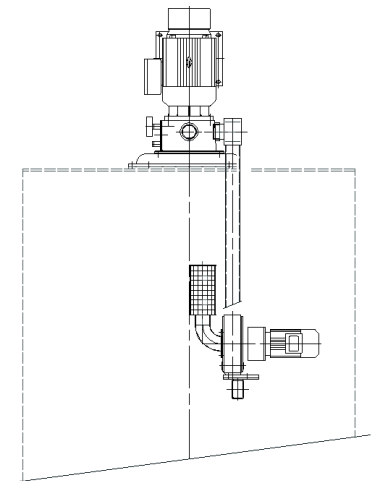

## Duyvis and Wiener

**B.V. Machinefabriek P.M. Duyvis is a machine-building company with more than 120 years of experience. It is situated in the oldest industrial region of the Netherlands where most of the cocoa and cocoa butter processing factories are located.**

**Duyvis** is specialized in engineering, producing and installing processing machines for the cocoa and chocolate industry. With its excellent engineering and mechanical team Duyvis holds an impressive record in providing innovative solutions to the industry in general and the cocoa and chocolate industry in particular.

Duyvis is also specialized in modifying, overhauling, repairing and maintaining all kinds of equipment worldwide. The Duyvis team is able to provide a technological solution to every problem, paying attention to preventive maintenance and striving to find the best technical solutions and operating practices.

Since 2004 **Wiener** is part of the Duyvis Group. Wiener is an innovative and dynamic company with a strong position in the cocoa, chocolate and confectionary market. It is worldwide recognized as manufacturer and supplier of cocoa and chocolate process machinery and turn-key projects for cocoa, chocolate/compound, ice cream, bakery and the candy industry.

Wiener and Duyvis engineers, start-up technicians and process development experts joined forces and are working side by side to guarantee process and product innovations. The integrated laboratory in Koog aan de Zaan is available for testing food products in general and cocoa, chocolate, cream and compound in particular. A database of more than 25 years of data is available.

The combined know-how of Duyvis and Wiener will ensure the continuation of the high quality standard as well as excellent service. This is the result of combining two companies, which have together more than 200 years of experience.

Contact us and we will help you reduce your processing costs of cocoa, compound and chocolate production.



COCOA, COMPOUND AND CHOCOLATE EQUIPMENT

[WWW.DUYVISWIENER.COM](http://WWW.DUYVISWIENER.COM)



P.O. Box 10  
1540 AA Koog a/d Zaan  
The Netherlands

Schipperslaan 15  
1541 KD Koog a/d Zaan  
The Netherlands

Phone: +31 75 6 126 126  
Fax: +31 75 6 158 377  
Email: [sales@duyviswiener.nl](mailto:sales@duyviswiener.nl)





**TASTE-CHANGER**  
CONCHING AND VAPORIZING EFFECT



**WIENER**